

Fuel Level Sender Installation Instructions

For Lever Arm Fuel Level Sender — 3-180Ω

VDO

1-800-265-1818

THE INSTRUCTIONS FOR INSTALLATION OF LEVER ARM FUEL LEVEL SENDER FOLLOW. USE IS RESTRICTED TO 12 VOLT NEGATIVE GROUND ELECTRICAL SYSTEMS. FOR WIRING INSTRUCTIONS, REFER TO THE INSTRUCTIONS THAT CAME WITH YOUR FUEL GAUGE.

Parts List

Item	Description	Quantity
1.	Fuel Level Sender (P/N 1 551 004 305)	1
2.	Float Arm	1
3.	Gasket and Hardware Kit	1

Tools and Materials Needed For Installation:

2¼" hole saw
 Drill and drill bit set
 Bolt cutter or similar tool
 Half-round file
 Tape measure or ruler
 Wrench or nut driver set
 Phillips screw driver
 Utility knife
 Gas-proof gasket sealant
 Bolt-on Installation Kit (optional) P/N 226 451

NOTE: If you are in doubt about any part of this installation procedure, please contact your dealer or VDO North America at 1-800-265-1818.

CAUTION: Read these instructions thoroughly before making installation. Do not deviate from assembly or wiring instructions. Always disconnect battery ground before making any electrical connections.

Fuel Level Sender Installation

The Fuel Level Sender has a resistance rating of 3Ω when the tank is empty and 180Ω when full. Refer to the VDO Catalog for matching fuel gauges. The unit can be adjusted to read accurately in tanks from 6" to 23" deep. For sender adjustment, refer to Table 1 and Diagram A.

I. Measure the depth of your fuel tank. Locate this dimension in Column "A" of Table 1. Column "B" then shows the length from the underside of the sender flange to the center of the float pivot. Column "C" shows the distance from the center of the float pivot to the center of the float ball. For example, a tank 12" deep would need a measurement of 6" from the flange to the pivot, and 7.8" from the pivot to the float.

II. For tank depths less than 18" it will be necessary to eliminate a part of the assembly. Otherwise, proceed to Section III. Refer to Diagram B and proceed as follows:

1. Remove nut "a," washer "b," and ring terminal "c" from the underside of the mounting flange.
2. Remove the two screws marked "d" and discard.
3. Remove the two screws marked "e" from the plastic housing and save for later use.
4. Carefully remove bracket "f" from the plastic

housing and discard. Replace it with bracket "g" in the housing and loosely re-install the two screws marked "e" into the housing.

5. Slide the housing up or down until the proper dimension from Table 1 is reached, then tighten the screws "e" securely.
6. Replace the ring terminal and its hardware.

CAUTION: Do not overtighten hardware, to avoid damage to the threads!

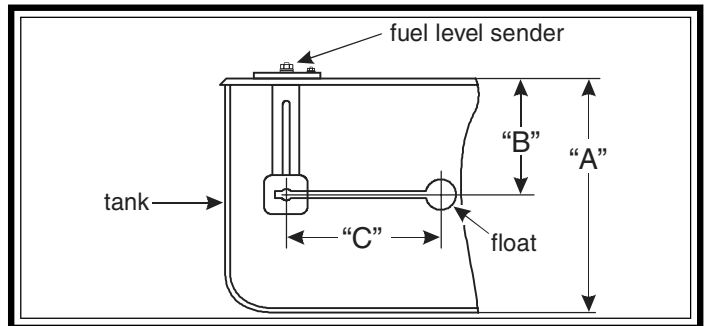

Diagram A

Measurements Needed To Make Proper Adjustments

TABLE 1 (dimensions in inches)

A	B	C	A	B	C	A	B	C
6.0	3.00	3.5	12.0	6.00	7.8	18.0	9.00	12.0
6.5	3.25	3.8	12.5	6.25	8.1	18.5	9.25	12.3
7.0	3.50	4.2	13.0	6.50	8.5	19.0	9.50	12.6
7.5	3.75	4.5	13.5	6.75	8.9	19.5	9.75	12.9
8.0	4.00	4.9	14.0	7.00	9.3	20.0	10.00	13.4
8.5	4.25	5.3	14.5	7.25	9.6	20.5	10.25	13.8
9.0	4.50	5.6	15.0	7.50	10.0	21.0	10.50	14.2
9.5	4.75	6.0	15.5	7.75	10.4	21.5	10.75	14.6
10.0	5.00	6.4	16.0	8.00	10.7	22.0	11.00	15.0
10.5	5.25	6.7	16.5	8.25	11.0	22.5	11.25	15.4
11.0	5.50	7.1	17.0	8.50	11.4	23.0	11.50	15.7
11.5	5.75	7.4	17.5	8.75	11.8			

!! IMPORTANT !!

As received, the unit will have a short lever arm installed. Loosen the screw and remove the short lever arm, and replace it with the long float arm and plastic float ball assembly. **When the installation is finished, the arm length to the left (short side) of the screw must be 1".**

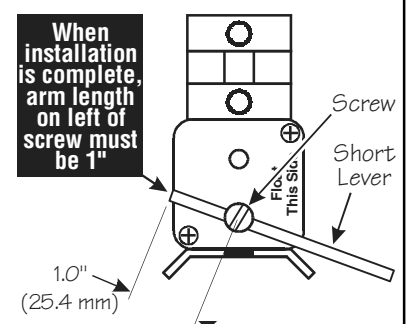

CAUTION: When attaching the float arm to the sender body, make sure the float ball is to the right side as you face the unit, as shown in Diagram B. If you attach the float arm to the left of the sender body, or backwards, the fuel gauge will read "FULL" when the tank is actually empty!

III. For tank depths of 16" to 23", no disassembly of the sender bracket is necessary.

1. Remove the ring terminal as instructed in Section II, above.

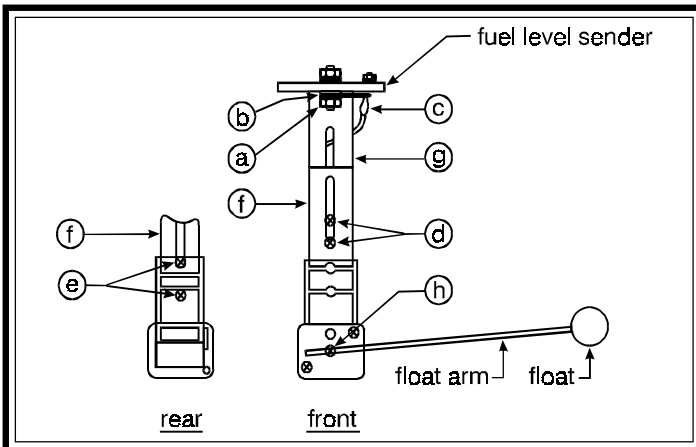

Diagram B

Parts of the Fuel Level Sender Unit to be Adjusted

2. Loosen the two screws marked "d." Adjust the plastic housing up or down until the proper dimension from Table 1 is obtained, then retighten the screws securely. **DO NOT** overtighten them.
3. Re-install the ring terminal and its hardware. Again, tighten the hardware securely, but **DO NOT** overtighten.

IV. To install the float assembly, loosen the screw marked "h," remove the short piece of rod, and discard it. Insert the float rod until the proper length—the "C" length from Table 1—is met, then tighten screw "h" securely. Carefully cut off any excess rod with a bolt cutter or similar tool, taking care not to damage the assembly.

NOTE: Make sure the float is installed as shown in Diagram B. Remember, if it is installed backwards, the fuel gauge will indicate "FULL" when the tank is actually empty, and vice-versa. Be sure to leave 1" on the short side of the arm.

V. Refer to Diagram C for installation of the fuel sender assembly into the tank. The sender flange is designed to fit a standard SAE hole pattern.

CAUTION: Before drilling any holes into the tank, place the sender assembly on top of the tank to judge the proper hole placement—one that will allow the float arm clearance inside the tank.

SAFETY PRECAUTION: When making modifications to fuel tanks, it is essential that the tank be removed from the vehicle, and that it is empty, clean and dry. After drilling, make sure all chips and other foreign matter have been removed from the tank. Clean the tank thoroughly.

If no holes exist in the fuel tank (see CAUTION, above):

1. Carefully mark an area to be cut open so you can insert the sender. The key to this step is to position the float as close as possible to the center of the tank. This provides the most stable and accurate reading when the fuel sloshes back and forth. Make sure you have allowed enough clearance for the float arm before you cut the hole. Remember, you only get one chance to do it right!
2. Cut a 1.697" (43 mm) hole in the top of the tank.
3. With the gasket in place below the flange, carefully feed the float arm and sender body into the 1.697" (43 mm) hole in the tank. Make certain the float arm has free motion within the tank. Using the sender flange as a template, locate the positions of the five mounting holes. Depending on the thickness of the tank, either self-tapping screws or #8-32 machine screws may be used, drilling and tapping accordingly. If threaded holes already exist, check the thread size and use the appropriate hardware.
4. Insert the fuel sender assembly into the tank. Align the holes and thread in the 1/2" mounting screws through the holes in the sender flange and tank. Check to make sure that all screws are secure. **AVOID OVERTIGHTENING!** When you have done this, the installation of the fuel level sender unit is complete.

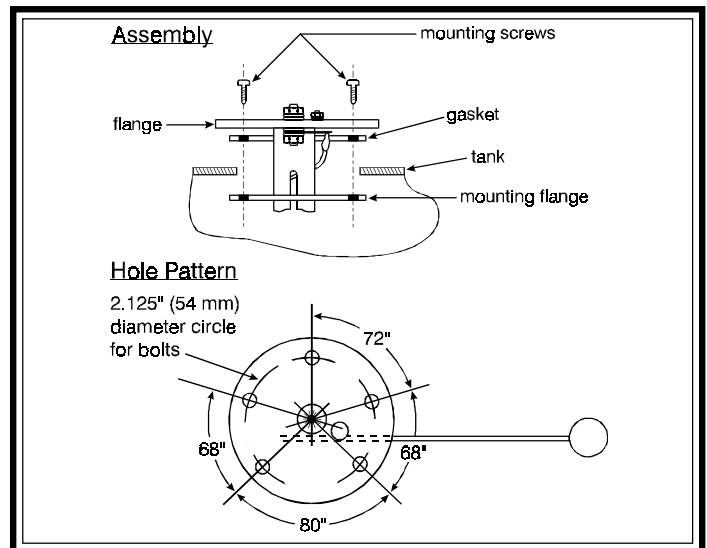

Diagram C

Fuel Sender Assembly and Hole Pattern Dimensions

Merchandise warranted against defects in factory workmanship and materials for a period of 24 months after purchase. This warranty applies to the first retail purchaser and covers only those products exposed to normal use or service. Provisions of this warranty shall not apply to a VDO product used for a purpose for which it is not designed, or which has been altered in any way that would be detrimental to the performance or life of the product, or misapplication, misuse, negligence or accident. On any VDO part or VDO product found to be defective after examination by manufacturer, manufacturer will only repair or replace the merchandise through the original selling dealer. Manufacturer assumes no responsibility for diagnosis, removal and/or installation labor, loss of vehicle use, loss of time, inconvenience or any other consequential expenses. The warranties herein are in lieu of any other expressed or implied warranties, including any implied warranty of merchantability of fitness, and any other obligation on the part of manufacturer, or selling dealer.

(NOTE: This is a "Limited Warranty" as defined by the Magnuson-Moss Warranty Act of 1975.)