



## Viewline Instrument Kit Installation Instructions

Tech Support 1-800-265-1818  
<http://vdo-gauges.com>

Instruction Sheet # A2C59519502

Rev C

Read these instructions thoroughly before installation. Do not deviate from assembly or wiring diagram. Always disconnect battery ground before making any electrical connections.

**IMPORTANT:** Mounting dimensions vary for different gauges. Please be certain to follow the instructions for your specific gauge.

### Kit Contents:

(1) 120mph electronic speedometer
(1) 8,000 RPM tachometer (6 gauge kits, only)
(1) 250F Temperature gauge
(1) 80 PSI oil pressure gauge
(1) E-F fuel gauge
(1) 8-16V voltmeter
(1) Oil pressure sender with integrated low pressure switch **
(1) Coolant temperature sender (1/8-18 NPTF threads)
(1) High coolant temperature switch (3/8-27 NPTF threads)
(1) Fuel sender with low fuel switch
(1) Speedometer sender
(1) Brass adapter for temperature switch (3/8-18 NPTF to 1/2x18 NPTF)
(2) Brass adapter kits for temperature sender and oil pressure sender*
(2) Momentary on/off buttons(1 button in 5 gauge kits)
(1) Wire Harness
(1) Instrument Kit Installation Instructions
(1) Fuel Sender Installation Instructions

\*Adapters are 1/4 inch, 3/8 inch and 1/2 inch. Engines requiring metric adapters, including Chevy LS1, use adapter kit 240 904, sold separately  
\*\*Some kits will substitute the pressure sender/switch with a separate oil pressure sender and separate low pressure switch

Merchandise warranted against defects in factory workmanship and materials for a period of 24 months after purchase. This warranty applies to the first retail purchaser and covers only those products exposed to normal use or service. Provisions of this warranty shall not apply to a VDO product used for a purpose for which it is not designed, or which has been altered in any way that would be detrimental to the performance or life of the products, or misapplication, misuse, negligence or accident. On any VDO part or VDO product found to be defective after examination by manufacturer, manufacturer will only repair or replace the merchandise through the original selling dealer. Manufacturer assumes no responsibility for diagnosis, removal and/or installation labor, loss of vehicle use, loss of time, inconvenience or any other consequential expenses. The warranties herein are in lieu of any other expressed or implied warranties, including any implied warranty or merchantability of fitness, and any other obligation on the part of manufacturer, or selling dealer.



### Important Installation Notes:

The harness included with this kit was designed to fit multiple vehicle and dash applications. Make sure to layout your instruments and trial fit the harness prior to installation. If alteration is required it is recommended you change instrument layout rather than making alterations to wire harness.

The included harness's black ground wire **must** be grounded to a chassis point that is not a shared ground with other electronics. Failure to ground to chassis or failure to isolate from other electronics (such as radio, engine computer, electric fans) **will** result in inaccurate gauge readings and possible instrument damage.

### Speedometer

#### Gauge Installation:

1. Select the desired mounting location of the instrument.
2. Depending on your mounting situation it might be necessary to configure/program the speedometer before installation.
3. Mount the gauge and secure with the VDO Spin-Lok™ Clamp. See page 14-15 for mounting options and instructions

#### Wiring the Gauge (Illustrations A & B):

1. See page 12-13 for wire harness hookup:
  - a) Speedometer signal source to open connection of 10 pin connector of supplied harness (see Illustration B). Signal source can be Hall Effect sender (included), or original equipment electronic control box.

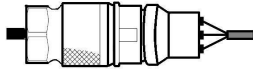

Included Hall Effect Sender (GM version shown)

Wire	Assignment
Red	+12V switched power
Black	Ground
White	Signal, to 10 pin wire harness connector as shown (Illustration B). using connector provided

**OR**

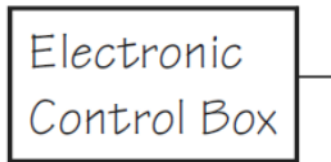

**Optional** hookup to the output wire of most electronically controlled transmissions. Connect output wire to open location shown in Illustration B at right, used for White Speedometer Sender Wire.

**NOTE:** Speedometer cannot be hooked up directly to an OEM 2 wire VSS (Vehicle Speed Sensor)!

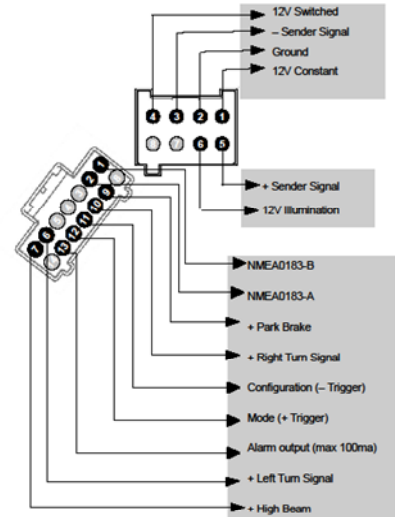

Illustration A

#### Wire Connector Reference

Connections will be made through provided harness pigtail, see page 12-13

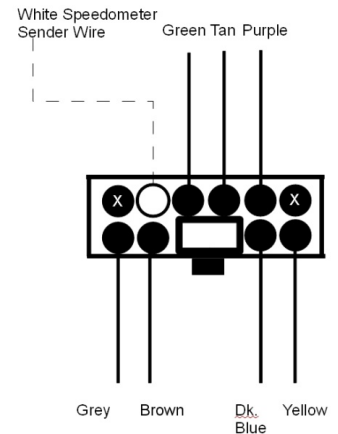

Illustration B

Attachment of speedometer signal wire to the harness's 10 pin connector. See page 11 and Table B on page 12-13

## Viewline Instrument Kit Installation Instructions

Tech Support 1-800-265-1818  
<http://vdo-gauges.com>

Instruction Sheet # A2C59519502

Rev C

**NOTE:** The push-button supplied is to be used as a:  
a) **Configuration** button to set up the speedometer before use (to tan wire of supplied harness, and to ground). This is a temporary connection.  
b) **Mode** button for operation of the speedometer during normal use (to light blue wire of supplied harness and +12V switched). This will be the permanent connection.

See Table A on page 13 for wiring instructions

### Programming the Speedometer (Illustration C):

Operation Basics:

Short Press (< 2sec.) - Long Press (> 2sec.)

The Configuration button must be connected before programming can be done.

The display will return to normal operation if a button is not pressed for 30 seconds. Any settings you have made will not be saved.

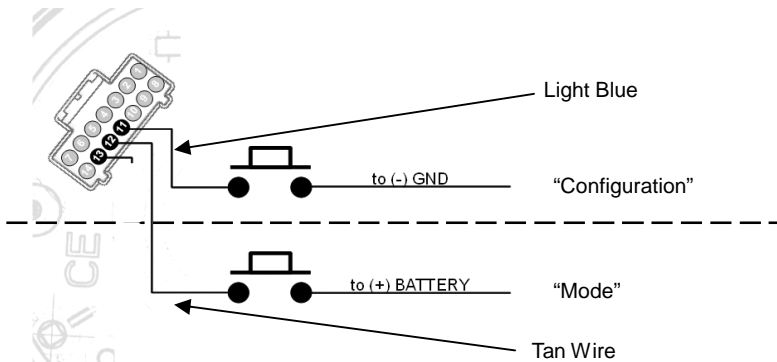

Illustration C

#### **Button Reference**

Connection to speedometer will be made through the provided harness pigtail, Table A page 13

### Setting the Speedometer Input:

1. With the ignition switch off, hold in the Configuration button
2. Turn ignition on
3. Release the Configuration button
4. "INPUT" will appear on the display
5. Long press to get to the Input setting screen
6. Short press to cycle through "FREQUE" or "NMEA"

NOTE: NMEA input requires no calibration.

7. Select "FREQUE", then long press to exit input setting
8. "INPUT" will appear on the display

### Calibrating the Speedometer (FREQUE Input) – Auto-calibration or Manual

#### Auto-calibration (Autocl):

The auto-calibration function can be used successfully on a road with the distance of one mile accurately designated. The road does not have to be straight.

1. While in configuration mode (Refer to step 1-8 above)
2. Short press to get to the "Autocl" setting screen.
3. Long Press to enter the Autocal menu– "button" will appear.
4. When you are ready to begin your calibration run, short press the button again. "000000" will appear on the display.
5. Drive the reference distance of one mile (or 1 kilometer). NOTE: As you drive this distance, the pulses will be displayed and the needle will move. If the Speedo is not counting pulses, no useable impulse is being detected.
6. After 1 mile (or 1 km), Short press. The number of pulses counted during the calibration run will be displayed.
7. Long press to save the pulse count and exit the auto-calibration ("PULSE" will appear on the display).
7. Turn off ignition. The speedometer is now programmed.

# Viewline Instrument Kit Installation Instructions

Tech Support 1-800-265-1818  
<http://vdo-gauges.com>

Instruction Sheet # A2C59519502

Rev C

## Manual Calibration:

1. While in configuration mode (Refer to step 1-8 above)
2. Short press twice - "PULSE" will appear on the display
3. Long press to get to the pulse setting screen
4. Short press will increase the value of the flashing number by 1.
5. Long press to move to the next position.
6. Continue until right most digit is set.
7. Long press to exit pulse setting.
8. "PULSE" will appear on the display.
9. Turn off ignition.

The Speedometer is now programmed. The button can be disconnected and rewired from "Configuration" to "Mode" as shown on page 12-13 and in Illustration C.



If you ever need to reprogram you speedometer, you will need to reuse the tan wire. It is recommended that you do not cut the wire. Tie wrap and secure the wire where it will not interfere with vehicle operation.

## Set Unit and Alarm Threshold:

1. With the ignition switch off, hold in the Mode button
2. Turn ignition on
3. Release the Mode button
4. "UNIT" will appear
5. Long press to enter UNIT menu
6. Short press to change the clock format. 12 hour am/pm - 24 hour
7. Long press to return to UNIT menu
8. Short press to show "WARN" on the display
9. Long press to enter WARNING menu
10. Short press to set Speed warning limit.
11. Short press will increase the value of the flashing number by 1 - Long press will move to the next position
12. Continue until right most digit is set.
10. Long press to exit.
11. Turn off ignition.

The Warning Icon in the gauge will illuminate when the Speed exceeds this limit.



## Mode Button:

In normal operating situations, Short press of the MODE button will cycle through:

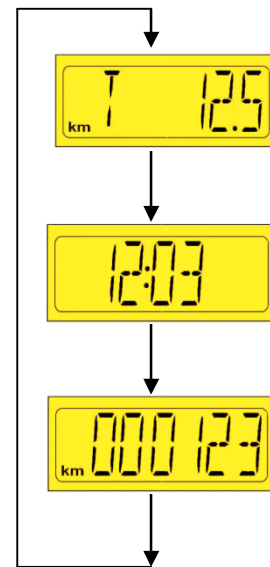

## Reset the Trip Distance:

1. Press the Mode key repeatedly until the trip distance is displayed.



2. Press and hold Mode key to reset.



## Viewline Instrument Kit Installation Instructions

Tech Support 1-800-265-1818  
<http://vdo-gauges.com>

Instruction Sheet # A2C59519502

Rev C

### **Setting the Time:**

1. Press the Mode key repeatedly until the clock is displayed.
2. Long press the Mode button to enter clock set mode.



3. Short press will increase the value of the flashing number by 1

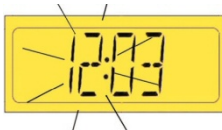

4. Long press to move to the next position
5. When finished, Long Press to return to clock display

*Note: If battery is disconnected, the clock will need to be reset.*

### **Set the Illumination intensity (1 to 10):**

1. Long press the Mode button while the Odometer is displayed to enter Illumination setting.



2. Short Presses will increase the value of the flashing number by 1.



3. Long press to save the Illumination setting and return to the Odometer display screen.

# Viewline Instrument Kit Installation Instructions

Tech Support 1-800-265-1818  
http://vdo-gauges.com

Instruction Sheet # A2C59519502

Rev C

## Tachometer (6 Gauge Kits Only)

### Gauge Installation:

1. Select the desired mounting location of the instrument.
2. Depending on your mounting situations it might be necessary to configure the gauge before installation.
3. Mount the gauge and secure with the VDO Spin-Lok™ Clamp. See page 14-15 for mounting options and instructions.

### Wiring the Gauge (Illustration D):

1. See page 12-13 for wire harness hookup:
  - b) Tachometer signal source to the purple lead wire. Signal source can be: the Ignition Coil (negative terminal), Alternator W terminal, Inductive , Generator , or the tachometer output wire of some Engine Control Modules
  - c) Signal source examples:

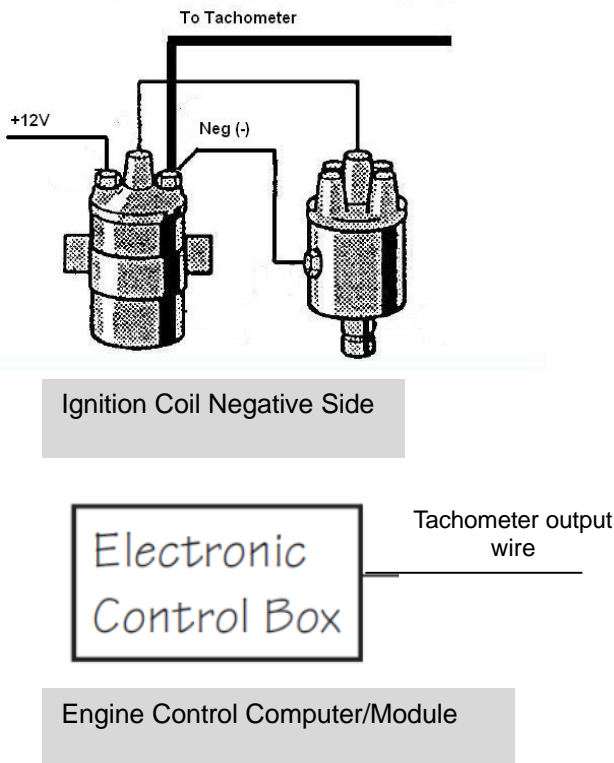

**NOTE:** The push-button supplied is to be used as a:

- a) **Configuration** button to set up the tachometer before use (dark blue wire of supplied harness and to ground). This is a temporary connection.
- b) **Mode** button for operation of the tachometer during normal use (grey wire of supplied harness and to +12V switched). This will be a permanent connection.

See Table A on page 13 for wiring instructions

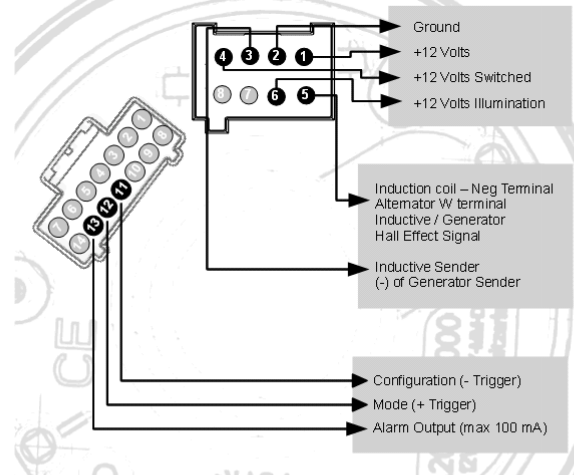

Illustration D

Wire Connector Reference

Connections will be made through provided harness pigtail, see page 12-13



## Viewline Instrument Kit Installation Instructions

Tech Support 1-800-265-1818  
<http://vdo-gauges.com>

Instruction Sheet # A2C59519502

Rev C

### Programming the Tachometer (Illustration E):

Operation Basics:

Short Press (< 2sec.) - Long Press (> 2sec.)

The Configuration button must be connected before programming can be done.

The display will return to normal operation if a button is not pressed for 30 seconds. Any settings you have made will not be saved.

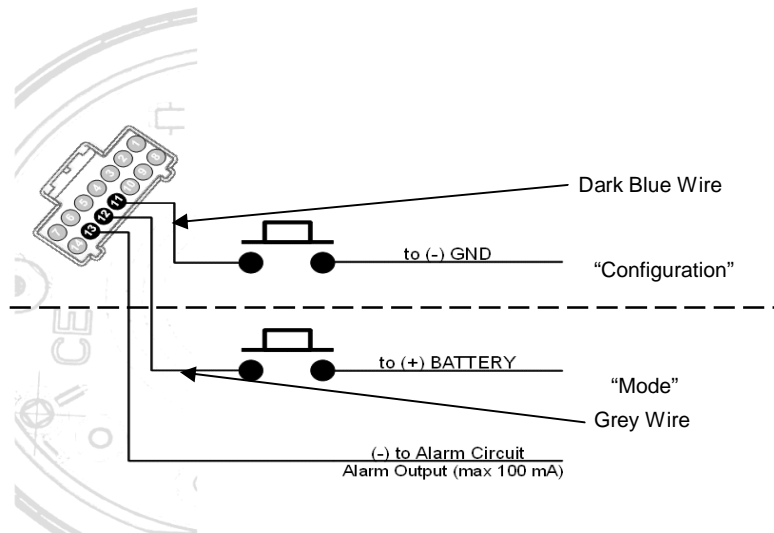

Illustration E

#### Button Reference

Connections to tachometer will be made through provided harness pigtail, Table A on page 13

### Setting the Pulses per Revolution: (0.5 to 399.9 pulses)

If you are using the negative side of the ignition coil as the signal source for the tachometer, the number of pulses is (in most applications) ½ the number of cylinders:

Most 4 cylinder applications = 2 pulses/revolution

Most 6 cylinder applications = 3 pulses/revolution

Most 8 cylinder applications = 4 pulses/revolution

If you are using the Engine Control Module for the signal source, consult the manufacturer's documentation for the number of pulses.

1. With the ignition switch off, hold in the Configuration button.
2. Turn ignition on.
3. Release the Configuration button.
4. "PULSE" will appear on the display.
5. Long press to get to the pulse setting screen.
6. Short press will increase the value of the flashing number by 1.
7. Long press to move to the next position.
8. Long press to exit pulse setting.
9. "PULSE" will appear on the display.
10. Turn off ignition.

The tachometer is now programmed. The button can be disconnected and rewired from "Configuration" to "Mode" as shown on page 13 and at left (illustration E).



If you ever need to reprogram you tachometer, you will need to reuse the dark blue wire. It is recommended that you do not cut the wire. Tie wrap and secure the wire where it will not interfere with vehicle operation.

### Set Unit and Alarm Threshold:

1. With the ignition switch off, hold in the Mode button
2. Turn ignition on.
3. Release the Mode button.
4. "UNIT" will appear.
5. Long press to enter UNIT menu.
6. Short press to change the clock format. 12 hour am/pm - 24 hour.
7. Long press to return to UNIT menu.
8. Short press to show "WARN" on the display.
9. Long press to enter WARNING menu.
10. Short press to set RPM warning limit.

(Continued on next page)

## Viewline Instrument Kit Installation Instructions

**Tech Support 1-800-265-1818**  
<http://vdo-gauges.com>

Instruction Sheet # A2C59519502

Rev C

11. Short press will increase the value of the flashing number by 1 - Long press will move to the next position.
12. Continue until right most digit is set.
13. Long press to exit.
14. Turn off ignition.

*The Warning Icon in the gauge will illuminate and the Alarm Output (green wire of the 14 pin connector of the wire harness) will trigger to ground when the RPM's exceed this limit.*

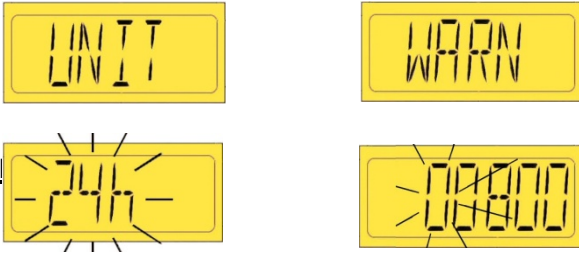

*In normal operating situations, short press of the MODE button will cycle through;*

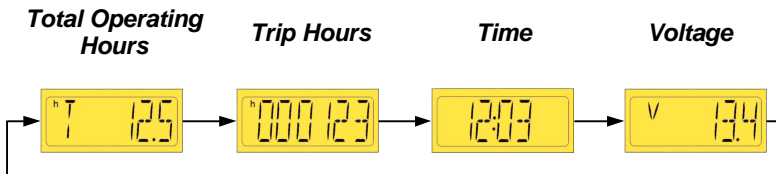

### Reset the Trip Operating Hours:

1. Press the Mode key repeatedly until the trip hours are displayed.
2. Press and hold Mode key to reset.



### Setting the Time:

1. Press the Mode key repeatedly until the clock is displayed.



2. Long press the Mode button to enter clock set mode.

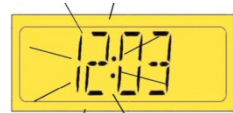

3. Short press will increase the value of the flashing number by 1.
4. Long press to move to the next position.
5. When finished, long Press to return to clock display.

*Note : If battery is disconnected, the clock will need to be reset.*

### Set the Illumination intensity:

1. Long press the Mode button while the Voltage is displayed to enter Illumination setting.



2. Short Presses will increase the value of the flashing number by 1.
3. Long press to save the Illumination setting and return to the Voltage display screen.



# Viewline Instrument Kit Installation Instructions

Tech Support 1-800-265-1818  
<http://vdo-gauges.com>

Instruction Sheet # A2C59519502

Rev C

## Voltmeter, Oil Pressure, Water Temperature & Fuel

### Gauge Installation:

1. Select the desired mounting location of the instrument.
2. Mount the gauge and secure with the VDO Spin-Lok™ Clamp. See page 14-15 for mounting options and instructions.

### Wiring the Gauge (Illustration F & G):

1. See page 12-13 for wire harness hookup.
  1. Oil pressure signal to dark blue wire of 10 pin connector. Oil pressure warning switch to yellow wire of 10 pin connector.
  2. Water temperature signal to green wire of 10 pin connector. Water temperature warning switch to tan wire of 10 pin connector.
  3. Fuel level signal to grey wire of 10 pin connector. Fuel level warning switch to brown wire of 10 pin connector.

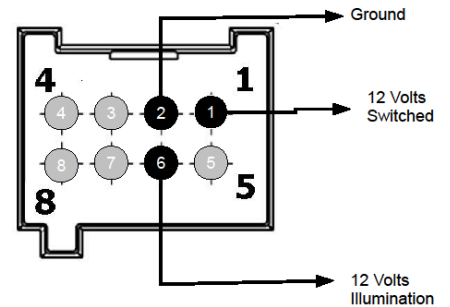

*Illustration F  
Voltmeter Reference*

*Connections will be made through provided harness pigtail, see page 12-13*

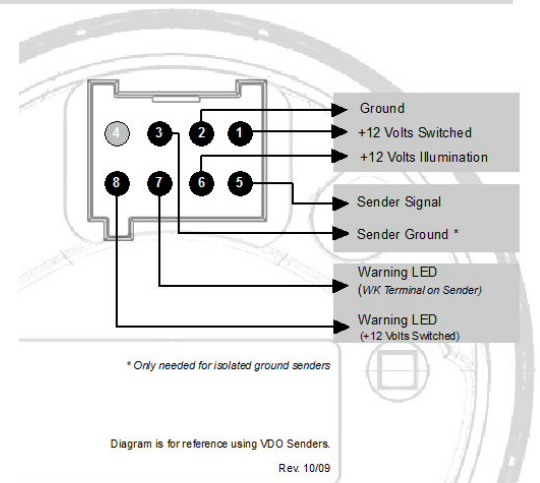

*Illustration G Reference  
Oil Pressure  
Water Temperature  
Fuel*

*Connections will be made through provided harness pigtail, see page 12-13*

# Viewline Instrument Kit Installation Instructions

Tech Support 1-800-265-1818  
<http://vdo-gauges.com>

Instruction Sheet # A2C59519502

Rev C

## All Sender connections are to made to wires of 10 Pin Harness Connector

Warning Contact (WK) Terminal to yellow wire

Signal (G) Terminal to dark blue wire

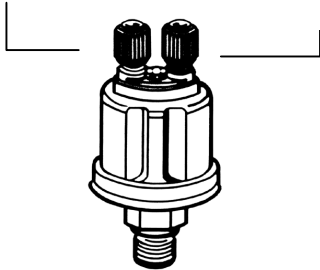

**Included Pressure Sender with integrated warning switch (10-180 Ohm)**

Note: Do NOT use Teflon tape or sealant on

Signal terminal to green wire



**Included Temperature Sender (1/8-18 NPTF Thread) Marking on hex 120°C, 801/5/1 (VDO Proprietary Ohm Range)**

Note: Do NOT use Teflon tape or sealant on threads!

OR

Signal (G) terminal to dark blue wire

Warning contact (NC) terminal to yellow wire

(C) Terminal ground

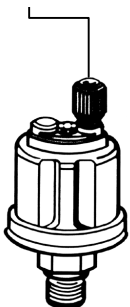

Pressure Sender

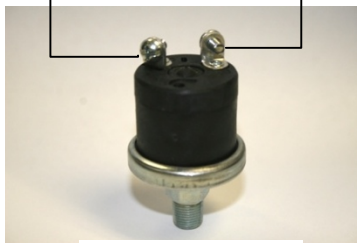

Pressure Switch

**Included Pressure Sender (240-33 Ohm) & Pressure Switch**

Note: Do NOT use Teflon tape or sealant on threads!

(kits featuring this sender will contain an oil pressure gauge with corresponding Ohm range)

Warning contact terminal to tan wire



**Included Temperature Switch (3/8-27 NPTF Thread) Marking on hex 120°C, 11/17/139**

Note: Do NOT use Teflon tape or sealant on threads!

# Viewline Instrument Kit Installation Instructions

Tech Support 1-800-265-1818  
<http://vdo-gauges.com>

Instruction Sheet # A2C59519502

Rev C

## All Sender connections are to made to wires of 10 Pin Harness Connector

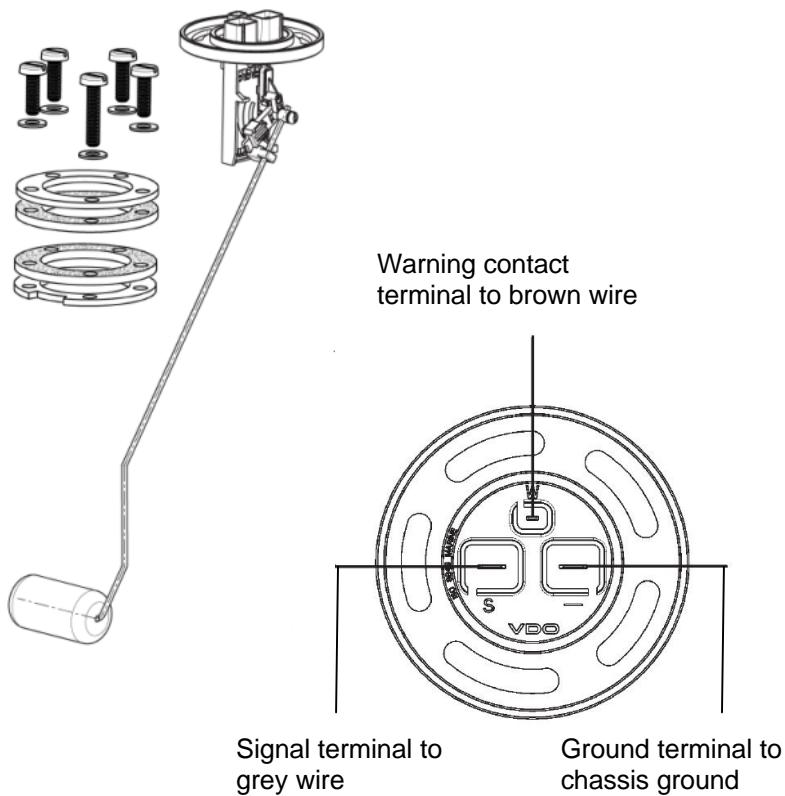

**Included Fuel Sender with Low Fuel Warning Contact (10-180 Ohm)**

Please see the separate instruction sheet included with kit for detailed installation instructions

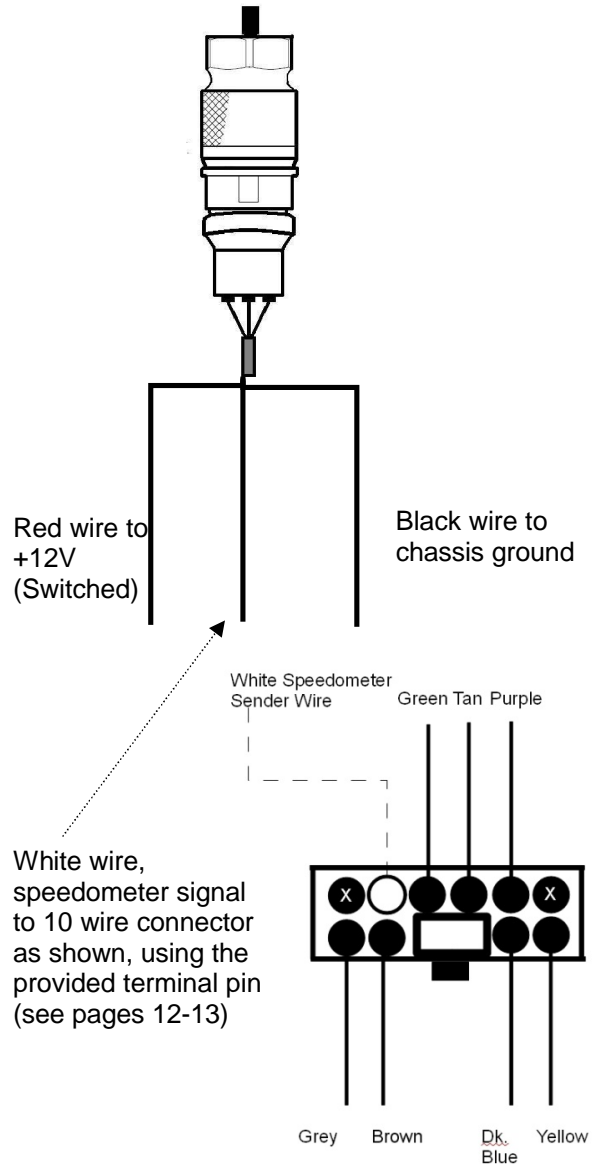

White wire, speedometer signal to 10 wire connector as shown, using the provided terminal pin (see pages 12-13)

**Included Speedometer Sender 16 pulse/revolution, weather sealed, reverse polarity protected Ford or GM style (GM style shown)**

# Viewline Instrument Kit Installation Instructions

Tech Support 1-800-265-1818  
<http://vdo-gauges.com>

Instruction Sheet # A2C59519502

Rev C

## Instrument Wiring Harness

The harness included with this kit was designed to fit multiple vehicle and dash applications. Make sure to layout your instruments and trial fit the harness prior to installation. If alteration is required it is recommended you change instrument layout rather than making alterations to wire harness.

### **IMPORTANT:**

*The black ground wire **must** be grounded to a chassis point that is not a shared ground with other electronics. Failure to ground to chassis or to isolate from other electronics (radios, electric fans, engine computers, etc.) **will** result in inaccurate gauge readings or possible damage to the instruments.*



## Connections to back of Instruments

Connectors for each instrument on the Main Harness are labeled accordingly. Insert connector into each instrument until it snaps into place. **Please note:** there are two connectors each for the speedometer and tachometer.

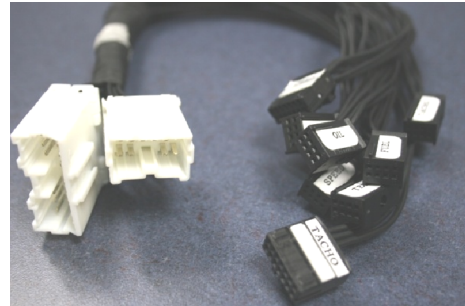
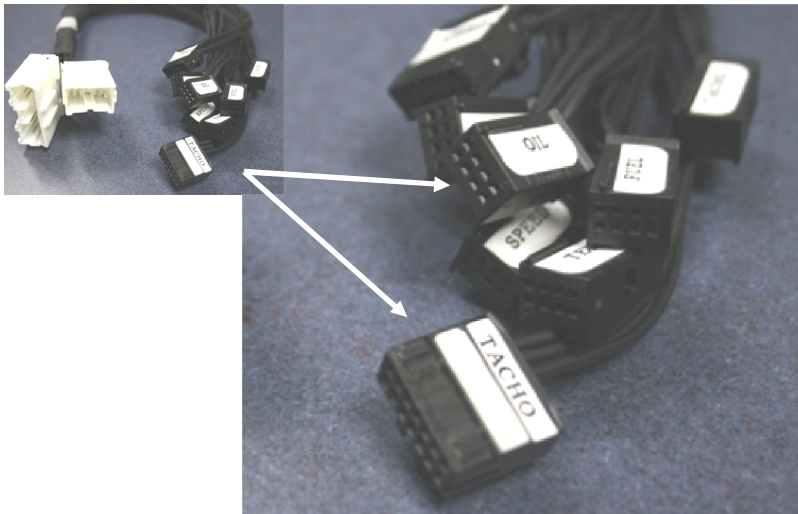

Instrument Connections (Main Harness)

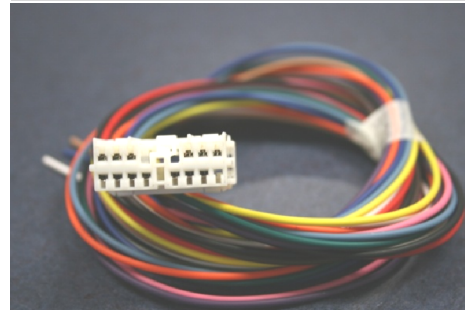

Under Dashboard Connections (14 Pin Harness)

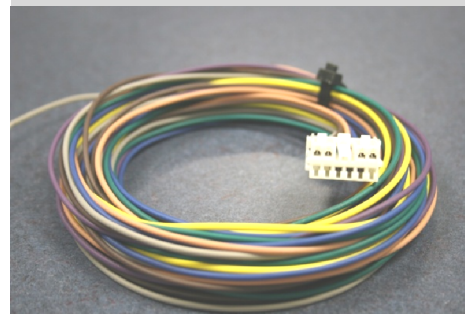

Through Firewall Connections (10 Pin Harness)



Connector pins for 10 pin harness to connect speedometer signal wire

## Viewline Instrument Kit Installation Instructions

**Tech Support 1-800-265-1818**  
<http://vdo-gauges.com>

Instruction Sheet # A2C59519502

Rev C

### Table A: Connections to Instruments

Connectors for each instrument are labeled accordingly. Insert connector into each instrument until it snaps into place. **Please note:** there are two connectors each for the speedometer and tachometer. Route the colored wires from the 14 pin connector, as shown. Connect the 14 pin Male connector to the corresponding 14 pin Female connector on the Main Harness.

<b>Under Dashboard Connector (14 Pin Connector)</b>	
Wire Color	Function
Red	+12V, Switched
Black	To Ground ( <i>see important note below</i> )
White	+12V, Illumination
Orange	+12V Constant, 5Amp Fused Power
Green	Alarm output from Tachometer (optional)
Dark Blue	To Ground through Tachometer Configuration Button (this is a temporary connection)
Grey	+12V Switched through Tachometer Mode Select Button (this will be a permanent connection)
Pink	+12V, Left Turn Signal
Brown	+12V, High Beam
Yellow	+12V, Emergency Brake
Purple	+12V, Right Turn Signal
Light Blue	To Ground through Speedometer Configuration Button (this will be a temporary connection)
Tan	+12V Switched through Speedometer Mode Select Button (this will be a permanent connection)

### Table B: Connections to Senders

Connect the colored wires of the 10 pin connector as shown. Use the included terminal pin to attach the white speedometer sender wire (or wire from transmission control module) directly to the wire harness connector, as shown. Connect the 10 pin Male connector to the corresponding 10 pin Female connector on the Main Harness.

<b>Through Firewall Connector (10 Pin Connector)</b>	
Wire Color	Function
Grey	Fuel Sender Signal
Brown	Fuel Sender Warning Contact (optional)
Dark Blue	Oil Pressure Signal
Yellow	Oil Pressure Warning Contact (optional)
Green	Water Temperature Signal
Tan	Water Temperature Warning Contact (optional)
Open Connection # 2. See diagram below	Speedometer Signal (white wire from speedometer sender cable)
Purple	Tachometer Signal

