



Viewline Pitot Speed/Fuel Gauge 110mm

Tech Support 1-800-265-1818
http://usa.vdo.com

Instruction Sheet # A2C59519677

Rev. A

Gauge Installation:

1. Select the desired mounting location of the instrument.
2. Depending on your mounting situation it might be necessary to configure the gauge before installation.
3. Mount the gauge and secure with the VDO Spin-Lok™ Clamp.
4. Refer to page 2 for mounting instructions.

Wiring the Gauge:

1. Route wires from the instrument to:
 - (a) The battery (+) after the ignition switch and after the fuse box or user supplied in-line fuse – 1 amp fast-blow.
 - (b) The light switch after the fuse box or user supplied in-line fuse -1 amp.
 - (c) A good, dedicated ground location, such as the engine block or negative side of the battery. **DO NOT USE A SHARED GROUND WITH ANY OTHER ELECTRONICS.**
 - (d) Signal wire from fuel sender. (10-180 ohm)
2. Connect the harness according to the following wiring Matrix:

8 Pin Connector (A)	
Pin	Description
1	Red – Battery Switched (+12V)
2	Black - Ground
3	Blue/Black - Fuel Sender Ground (optional)
4	Brown – unassigned
5	Green – Fuel Sender Signal
6	Blue/Red - Illumination (+)
7	Yellow/Black – unassigned
8	Yellow/Red – unassigned
Note - Use 18 AWG for wire harness	

Note: Receptacle (B) for 14 pin connector is not used

Gauge Hookup:

1. Route the tube (not included) from the pitot sender to the gauge
2. Push the tube onto the fitting on the back of the gauge

Read these instructions thoroughly before installation. Do not deviate from assembly or wiring diagram. Always disconnect battery ground before making any electrical connections.

Parts List		
Item	Description	Qty
1	110mm Gauge	1
2	Spin-Lok™ Clamp	1
3	8 pin Harness	1
4	Instruction Sheet	1

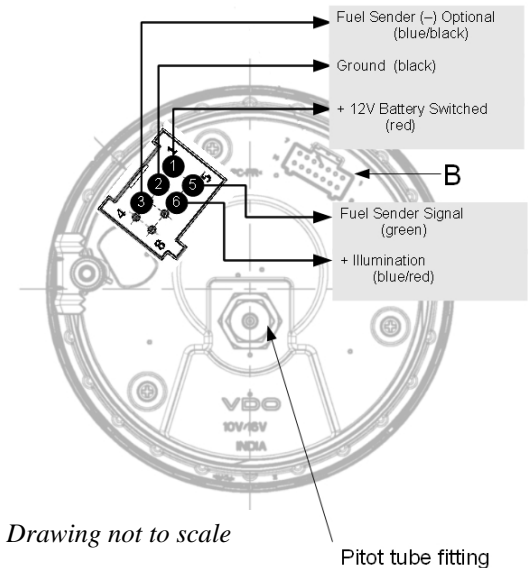

Drawing not to scale

Pitot tube fitting

Merchandise warranted against defects in factory workmanship and materials for a period of 24 months after purchase. This warranty applies to the first retail purchaser and covers only those products exposed to normal use or service. Provisions of this warranty shall not apply to a VDO product used for a purpose for which it is not designed, or which has been altered in any way that would be detrimental to the performance or life of the products, or misapplication, misuse, negligence or accident. On any VDO part or VDO product found to be defective after examination by manufacturer, manufacturer will only repair or replace the merchandise through the original selling dealer. Manufacturer assumes no responsibility for diagnosis, removal and/or installation labor, loss of vehicle use, loss of time, inconvenience or any other consequential expenses. The warranties herein are in lieu of any other expressed or implied warranties, including any implied warranty or merchantability of fitness, and any other obligation on the part of manufacturer, or selling dealer.

VDO

110mm

Conventional (Included)

Instrument is put into the drilled hole from the front. The maximum panel thickness is 20mm. The drilled hole must have a diameter of 111mm.

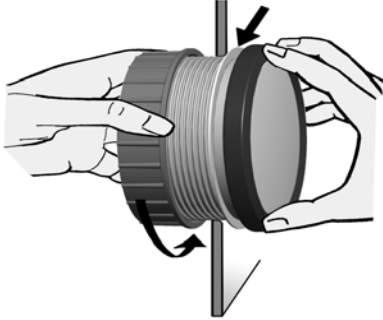

For 110mm instruments, the Spin-Lok™ nut can be mounted at position A or B. This allows you two clamping depths.

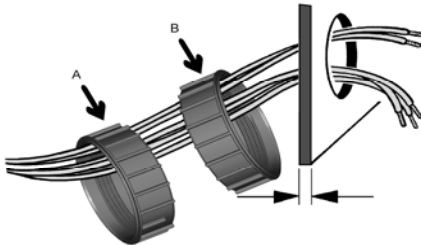

Version A
10mm

Version B
20mm

Flush (Optional)

When flush mounting (i. e., from the back so that the instrument glass and the panel form one plane), the front ring must be removed. Press on the instrument glass with both thumbs, while at the same time pulling the front ring forward from the instrument with both index fingers.

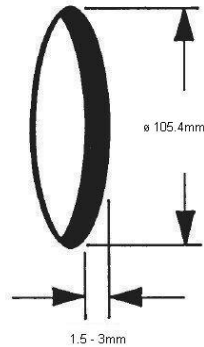

The recommended panel thickness is 1.5 to 3 mm. The drill hole must have a diameter of 105.4mm. Ensure that the installation location is level and has no sharp edges.

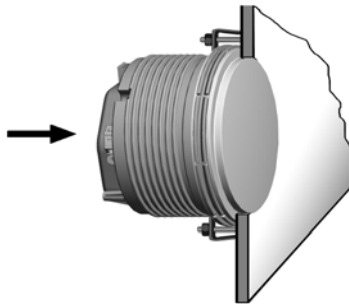

Place the flush mount seal on the instrument glass. Put the instrument into the drill hole from the back. Adjust the instrument so that the gauge is level and fasten it to the stud bolts (not included) on the rear side of the panel, using the flush mount fixing brackets.

Stud (Optional)

If you would like to omit the fastening nut, you may use the stud mount as an alternative. This is recommended if the installation location is subject to extreme vibrations.

Screw the stud bolts into the drilled holes on the rear of the instrument housing. Max. stud bolt torque is 1.5Nm.

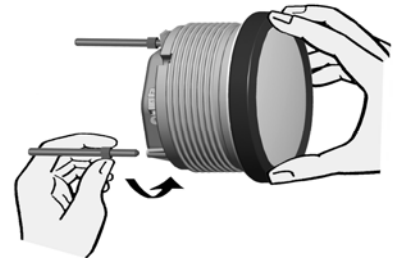

Place the bracket on the stud bolt and tighten the knurled nut. Do not over-tighten.

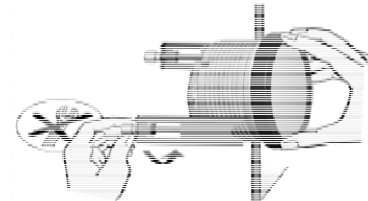

Tech Support 1-800-265-1818
<http://usa.vdo.com>